

## Integrated power scheme simulator for human-system integration studies

Rizah Memisevic<sup>1</sup>, Sanjib Choudhury<sup>2</sup>, Penelope Sanderson<sup>1</sup>, and William Wong<sup>3</sup>

<sup>1</sup> Cognitive Engineering Research Group, The University of Queensland, QLD

<sup>2</sup> Snowy Hydro Limited, Cooma NSW

<sup>3</sup> Interaction Design Centre, Middlesex University, UK

### Abstract

We present a simulator of a hydropower company's view of its scheme, and its broader market and network context, which has been developed to evaluate advanced displays for control room operations. Although simplified, the simulator captures all the main aspects of scheme operations. The simulator allows controlled studies to be performed that test the effectiveness of current vs advanced display concepts under normal vs unexpected operating conditions that can be scripted into the simulator.

### 1. INTRODUCTION

The introduction of the National Electricity Market (NEM) in Australia has required many generating companies to install new SCADA systems and new information and communications technology, or to undertake major upgrades, to participate in the NEM. For many companies this has produced an accretion of information systems in the control room over a relatively short time. The continuing rapid development of the market has not provided much opportunity for the systematic design of information displays for control room personnel. Companies that have initiated continuous improvement teams to address such problems find that they are addressing problems *de novo*—little is available in the way of industry best practice. Many of the problems are so new that substantial inventiveness is required to provide information that will support monitoring, decision making and intervention most effectively.

The authors have been exploring what the multidisciplinary area of *cognitive engineering* can bring to the problem of providing information representations for human controllers responsible for scheme monitoring and control. Cognitive engineering is concerned with the analysis, modelling, design, and evaluation of complex sociotechnical systems that are supervised in real time by human controllers [1-3] such as power plant control, emergency response, air traffic control, chemical process control, and so on. The goal of cognitive engineering is to develop principles and practices that will help us design complex sociotechnical systems that provide a better fit between human controllers and the systems they control, not

only under normal operating conditions but also when the unexpected happens.

A key contributor to such capability is the design of information representations that not only show current operating points, but that show those points in the context of the (1) first principles of operation of the system, (2) the physical and engineering constraints on its operation, (3) boundaries of safe operation determined during practice, (4) immediate past operating points and (5) possible future operating points. As Hollnagel has stated, a control room must be "a room with a view" of all the above [4]. We have been working on identifying the form of advanced displays that will not only provide the "view" of scheme operations that Hollnagel posits, but will also integrate the different areas of concern more effectively [5].

To support this goal, we have been developing a simplified simulator of scheme operations that will allow us to conduct human-in-the-loop evaluations of advanced display concepts. In the present paper we provide some information about the general form of our simulator, and indicate how we can use it for evaluating new display concepts.

### 2. INTEGRATED SCHEME SIMULATOR

A wide variety of simulators already exists for investigating many aspects of electrical power generation, dispatch, transmission, and market behaviour [6-14]. Such simulators often come with powerful visualisation capabilities that support problem-solving in each of the above areas. To the best

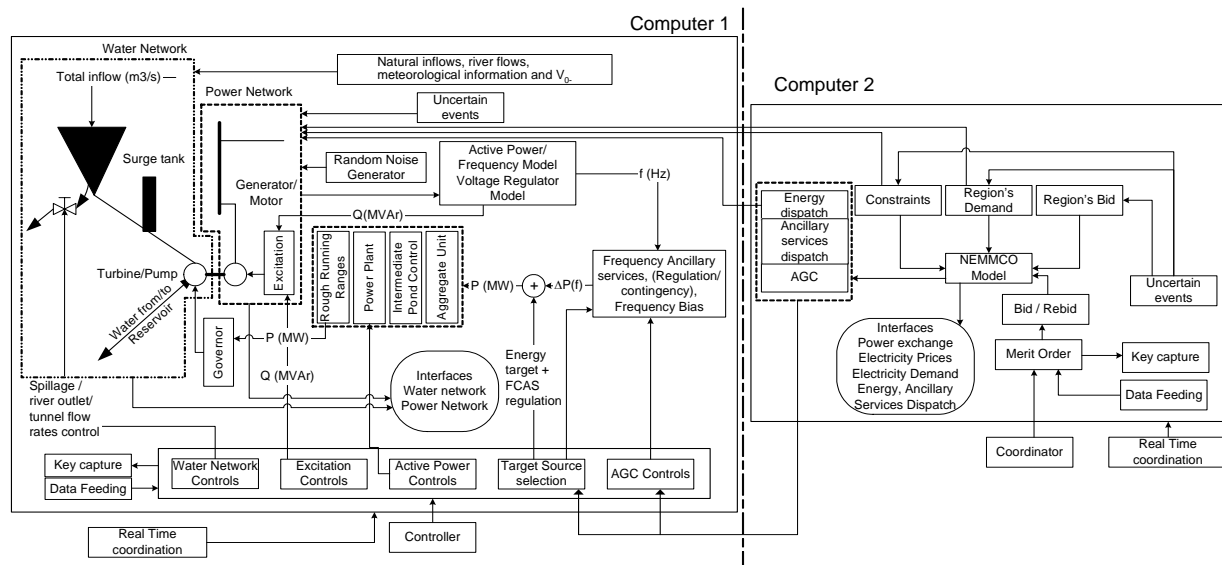

Figure 1: Overview of the integrated scheme simulator

of our knowledge, however, simulators that integrate all these factors from the generating company's point of view are more rare. There is a marked lack of integration offered by major providers of control room information system between the areas listed above. Properties emerge from the unique combination of the above factors that are known by controllers but that often do not find direct expression until controllers themselves provide it. To design for and test displays that integrate these areas, we need a testbed that simulates the functional and temporal properties of scheme control in the context of the market and the network.

Using MatLab, Simulink, Excel, Visual Basic and ActiveX Controls, we have developed a simplified and highly portable simulator of a generating company's scheme operations and its view of its market environment and electrical network. Although developed for the purpose of evaluating advanced display concepts, the simulator has enough fidelity to be a potential first-line training tool for novice controllers. Figure 1 shows the overall architecture of the simulator, which runs on two networked computers.

The allocation of functions to Computer 1 and Computer 2 roughly parallels the principal (but not exclusive) preoccupations of the control room controller and coordinator, respectively (see Figure 1). Computer 1 runs a simulation of scheme operations, including simulation of the Water Network, Power Network, and associated control systems and interfaces. The control system includes Water Network Controls, Excitation Controls, Active Power Controls, AGC Controls

(Automatic Generation Control), Target Source Controls, Rough Running Ranges Control, and Intermediate Pond Controls. Our simulator requires participants to operate plant as they normally would. The 36 screens developed to represent the baseline "current" interface should adequately support the participant during the simulation. The screens are as fully functional as the real ones.

Computer 2 runs a simulation of the NEMMCO (National Electricity Market Management Company), including a facility for bidding and rebidding. The Region's Demand, Region's Bid and Transmission Constraints are inputs into the simulator. These data can be the historical data from NEM but also can be data for a hypothetical situation in electricity market. Bidding and rebidding consists of two steps: development of the merit order and development of the bid. The coordinator is responsible for developing the merit order. The simulator then constructs the bid according to the entered merit order and submits it to the NEMMCO model. The scheduling process repeated every 5 minutes establishes the balance between supply and demand in the market. Cost-efficiency of supply is prioritized in dispatch. The NEMMCO model is based on optimal load flow calculation. The outputs from NEMMCO model are energy dispatch, ancillary service dispatch, power exchange between NEM regions, the regions' electricity prices and AGC signals. Transmission constraints data, regions' demand, energy and ancillary services dispatch and AGC signals are exchanged between Computer 1 and Computer 2 through network

DDE (Direct Data Exchange) communication. These data feed the simulation of scheme operation. Some data such as regions' demand and transmission constraints will directly change the status of the simulated system. Other data such as energy and ancillary services dispatch and AGC signals will differ depending on the controller's actions.

Several components of the simulator require further explanation: the power system model, the water network model, and the electricity market (NEMMCO) model.

## 2.1. Power system model

The simulation of the power system and the relations in its functional model are outlined in Figure 1. The simulated power system consists of five interconnected regions (networks): SA, Victoria, Snowy, NSW and QLD. The transmission system of the Snowy Region is fully modeled. The external network—SA, Victoria, NSW and QLD—are modeled by an equivalent network representation. The equivalent network model consists of an equivalent load and equivalent generator model. It is assumed that all generation sources and motor loads within the network swing together with an average frequency. Regions isolated from the Australian electricity market are modelled by a separate frequency model. These models represent the power system under steady-state operations as well as during medium and long-term dynamic regimes [15].

The power system is normally beyond the control of the human controller during short-term dynamic regimes. Hence, the behavior of the power system during fast transients is not simulated. System dynamic changes are simulated within a resolution of 2 s. The model used is shown on Figure 2.

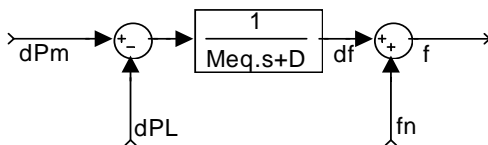

Figure 2: Frequency model

The equivalent generator has an inertia constant  $M_{eq}$  equal to the sum of the inertia constants of all generating units. Similarly, the effects of system loads are lumped into a single damping constant  $D$ . The total load change and change of total mechanical power are respectively:  $dP_L$ ,  $dP_m$ . In Figure 2  $f_n$ ,  $f$  and  $df$  are respectively nominal, instantaneous and change of frequency.

Our network model includes the major network components such as transformers, transmission lines. A power flow calculation program is used to calculate

network power flows, losses, and voltage on the busses. During real time simulation, the power flow calculation normally runs every 4 seconds to provide instantaneous flows, losses and bus voltages. The flows and voltages within the network are determined using the Stott power flow calculation. The voltage regulator model is used to simulate the voltage regulator behavior of a generator unit in any mode: generator, synchronous compensator or pump.

Ancillary services should minimize deviations of frequency and voltage—key power system parameters—from their designated values. Unlike frequency control, the control of system voltage through the generation or absorption of reactive power is not totally automated. A market for reactive power is still not fully established. The dispatch for this ancillary service comes as a direct phone contact between the NEM dispatch center and the scheme control center.

In our simulation, power system frequency is controlled using Fast, Slow, Delayed, and Regulation Raise and Lower FCAS (Frequency Control Ancillary Services). Regulation Raise or Lower FCAS control system frequency in response to variations in system demand within a dispatch interval. The dispatch targets for these services come through the AGC. Fast, Slow and Delayed contingency services are insurance type products & work over different time periods.

- Fast FCAS increases over the period from 0s after disturbance up to 6s and declines over next 60s.
- Slow FCAS increases over the period from 6s after disturbance to 60s and declines over next 5 min.
- Delayed FCAS increases over the period from 60s after disturbance to 5 min. and holds steady for up to next 15 min or manually stopped earlier.

All Contingency FCAS have a generic form that consists of several parameters: the Start Delay, Ramp Time, Hold Time and Unload Ramp Time, Trigger Frequency. Start Delay specifies the time that should elapse before the FCAS is applied. Ramp time specifies the time that should elapse before the FCAS enabled value is fully reached. Hold Time specifies the time that should elapse while the enabled FCAS MW is applied. Unload Ramp Time specifies the time that should elapse as the FCAS is reduced to zero. The Trigger frequency is the frequency at which will initiate the associated FCAS. Constraints on when FCAS can be retriggered reflect what happens in reality. The different offsets for FCAS for the frequency deviation are specified by the relationship between the elapsed time if and after the FCAS has been triggered for the type of FCAS enabled. Over and above the FCAS in the NEM, generators are

required to have governor response capability expressed in speed droop characteristic of 10% or lower (Lower values of percentage speed droop represents higher governor response). In the simulation this is set to be a speed droop characteristic of 10% in the generators. The sum of the FCAS offsets and the generating units' response to deviation in frequency is equal to  $\Delta P(f)$ . The sum of the  $\Delta P(f)$  and Energy target + FCAS regulation is the total generation of a aggregate unit.

The allocation of generation between hydropower plants within an aggregate unit is managed according to Intermediate Pond Control. The controller can change the simulation's Intermediate Pond Control mode and its parameters. The participation of a generating unit in a hydropower station's generation depends on unit regulating abilities, unit efficiency and unit control mode.

In addition, hydro units have usually several rough running zones. Running in these zones causes higher future maintenance costs. The simulated AGC manages rough running zones by quickly moving generation out of the rough running zone. The governor will be driven by this signal. The Random Noise Generation simulates uncertainty of generation and demand.

## 2.2. Water network model

Our simulation uses five generalized water network model components: reservoirs, hydro units, surge tanks pipes (tunnels) and valves (gates). As shown in Figure 3, the generalized block diagram of a reservoir has four input values: total inflows, total outflows, temperature,  $V_0$ . and one output elevation.

Reservoir flows are defined as follows:

- Total inflows = Natural inflows (precipitation)+ Flows received from pipes (tunnels)/hydro units/river
- Total outflows = Unit generation/ pumping discharges + releases (spillage, river outlet)+ diverting (tunnels)

The natural inflows, river flows, temperature and  $V_0$ . are given for each simulation scenario and are stored in a spreadsheet. The temperature is a local temperature at the reservoir and  $V_0$ . is the volume of the reservoir at the start of the simulation. Each reservoir specifies volume with a curve versus the elevation. The corresponding elevation is calculated by a linear interpolation based on the given curve.

Each simulated hydro unit is specified with a relationship between hydro unit output (MW) and the

discharge rate ( $m^3/s$ ). Each pumped water storage system is specified with the pump discharge rate curve. The hydraulic model of the surge tank shown in Figure 4 and it includes representation of penstock dynamics, surge chamber dynamics, tunnel dynamics, and penstock, tunnel and surge chamber orifice losses. The traveling wave effects in the penstock are included in the model [16].

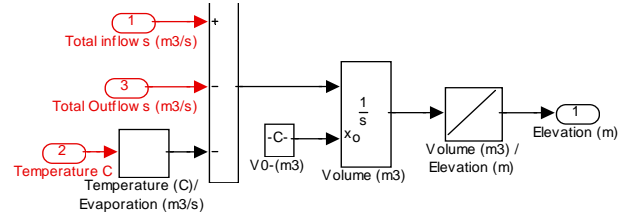

Figure 3: Reservoir model

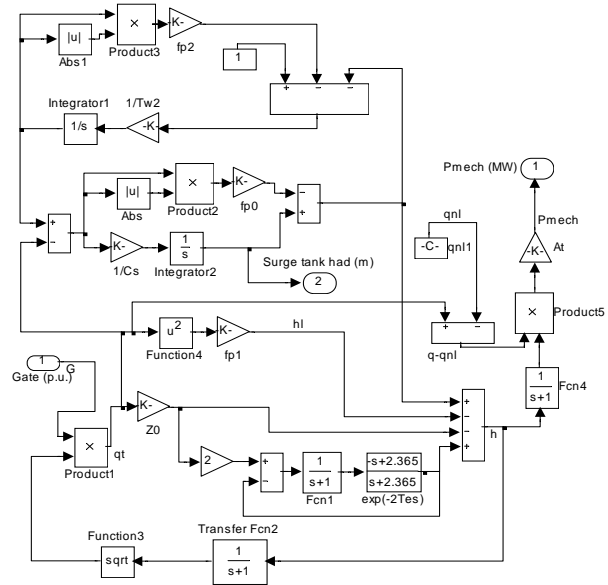

Figure 4: Surge tank model

For pipe network calculations the quantity balance method is used [17] which calculates the quantities flowing in each pipe when head at various points in a pipe network is known. A valve (gate) loss coefficient changes nonlinearly from the fully closed to fully open position. Valves are specified with a relationship between the position and the loss coefficient.

## 2.3. Electricity market model

The electricity market model emulates the output behaviour of the electricity market on the basis of key inputs. The inputs are regions' demand, regions' bid, the simulated hydro generating company's bid and general constraints.

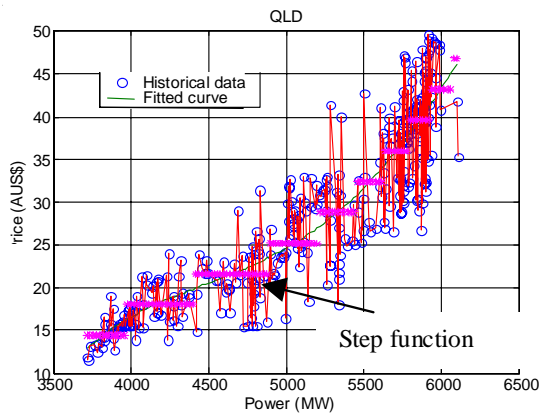

Figure 5: Development of the bid function

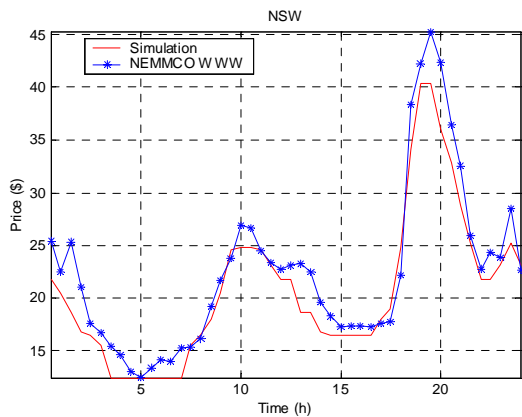

Figure 6 Historical (NEMMCO website) vs simulated prices for the test day.

The bids for each region have been developed based on the historical databases for demand and price in that region for a specific time period. The first stage of modeling involved fitting a curve to the historical data. The second stage involved creating a step function to approximate the curve (see Figure 5). The step function is then used as a bid for any specific region.

Usually the generating companies bid in a manner that will cover both fixed and variable costs. Of course deviations from that principle could be observed in the dynamic NEM due to interaction of various other factors influencing participant bids beyond the purview of this study. Use of a static bid for the regions was not appropriate. To simulate regional bidding more accurately it was necessary to change the regions' bid dynamically according to market demand.

Our model has been tested on historical data for 22 September 2002 (from the NEM website). Figure 6 shows the price curve for the observed day. The

simulation curve follows the curve from the NEMMCO historical database in the low and high price regions with relatively small error.

### 3. HUMAN-SYSTEM INTERFACE EXPERIMENTS

Our ultimate goal is to use the simulator to perform empirical studies that will test whether advanced displays support more effective human-system integration. We hypothesize that displays constructed according to cognitive engineering principles should lead to better situational awareness not only under normal operating conditions but also particularly under abnormal operating conditions. To run these studies, we must be able to control scenarios, capture data, and replay events for review.

#### 3.1. Scenarios, data capture, and replay

Our simulator requires participants to act as they normally would in real time—bidding and rebidding to NEMMCO as market conditions change, waiting to be dispatched, following the dispatch, optimising water use, and ensuring operation of the scheme in a safe and secure manner. Uncertainties associated with the market's response to system events are captured in the simulator, as well as the appropriate time constants for operation of scheme plant.

An important functional component of the simulator for experiments with human controllers is the ability for researchers to “script” incidents to occur at specific points in time. Examples are sudden transmission constraints, load shedding, or major scheme equipment failures. There are two files—one on each computer—that schedule incidents during the simulation.

In order to review human interaction with the simulator, we must capture people's activities. Two different segments of the simulation contribute to this. First, the “Key capture” subprogram collects all entered data with the time stamp. Second, the simulator has a “replay” capability for purposes of analysis, where control activity by controllers and/or /coordinators can be captured and replayed into a separate run of the simulator, producing the same event stream for analysis. During replay the “Data feeding” subprogram inserts the data according to the recorded time stamp. In addition, we videotape sessions so that verbal communications and team interactions can be reviewed in parallel with the simulator replay capability.

#### 3.2. Initial test of simulator

A preliminary version of the simulator was installed on two Dell laptops for transportation to the industry site,

where the laptops were supplemented with two 21" monitors. In this form it was evaluated by three pairs of scheme controllers/coordinators for its physical realism and for how well our version of the "current" displays serve as a baseline for comparing performance with "advanced" displays.

After familiarisation, controllers and coordinators experienced a scripted incident and worked together to resolve the situation. Apart from a few shortcomings in the calibration of the simulator and in the version of the "current" displays used at the time, participants considered that the simulator had sufficient realism and complexity to provide valid evaluations of advanced display concepts through human-in-the-loop simulation. We have updated the "current" displays and corrected any shortcomings noted. We have now proceeded to the design of advanced displays that will link water management, generation, transmission, and market information in ways that better support controller problem-solving.

#### 4. CONCLUSIONS

We are satisfied that an integrated view of hydropower scheme operation and its real-time coupling with the electricity market and the electricity network can be simulated to a medium level of fidelity in a highly portable configuration. Our simulation provides an excellent testbed for investigating a variety of issues related to human-system integration, including training, evaluation of displays, and team coordination during contingency management, amongst others.

#### 5. ACKNOWLEDGMENTS

This research was funded by ARC SPIRT grant C00107069 to Sanderson and Wong. We thank the Snowy Hydro Limited personnel who have contributed.

#### 6. REFERENCES

- [1] E. Hollnagel, *Handbook of cognitive task design*. Mahwah, NJ: Lawrence Erlbaum Associates, 2003.
- [2] J. Rasmussen, *Information processing and human-machine interaction: An approach to cognitive engineering*. Amsterdam: North-Holland, 1986.
- [3] K. Vicente, *Cognitive Work Analysis: Toward Safe, Productive, and Healthy Computer-Based Work*. Mahwah, NJ: Lawrence Erlbaum Associates, 1999.
- [4] E. Hollnagel, "A room with a view," ARC Key Centre for Human Factors Winter School, July 2002, Emanuel College, The University of Queensland, St Lucia, Qld, 2002

- [5] P. Sanderson, W. B.-L. Wong, S. Choudhury, and R. Memisevic, "Hydro scheme control in a deregulated environment. Cognitive work models and design implications.," Proceedings of the 47th Annual Meeting of the Human Factors and Ergonomics Society., Denver, CO, 2003.458-462
- [6] J. Contreras, A. J. Conejo, S. de la Torre, and M. G. Munoz, "Power engineering lab: Electricity market simulator," *IEEE Transactions on Power Systems*, vol. 17, pp. 223-228, 2002.
- [7] A. Martini, P. Pelacchi, L. Pellegrini, M. Cazzol, A. Garzillo, and M. Innorta, "A simulation tool for short term electricity markets," 22nd IEEE Power Engineering Society International Conference, 2001.112-117
- [8] N. Wang, R. Cheung, G. Wu, J. Naccarino, and J. Castle, "Simulation of the New York Power Pool for dispatcher training," *IEEE Transactions on Power Systems*, vol. 9, pp. 2063-2072, 1994.
- [9] A. Debs, C. Hansen, and Y.-C. Wu, "Effective electricity market simulators," *Computer Applications in Power*, vol. 14, pp. 29-34, 2001.
- [10] J. Kumar and G. Sheble, "Auction market simulator for price based operation," *IEEE Trans Power Systems*, vol. 13, pp. 250-255, 1998.
- [11] C. Demjen, P. Kadar, P. Meszaros, and D. Szendy, "An enhanced dispatcher training simulator," MELECON'94, Antalya, Turkey, 1994.992-995
- [12] C. Demjen, P. Kadar, P. Meszaros, and D. Szendy, "An integrated dispatcher training simulator for use in a regional electricity distribution centre.," *Control Eng Journal*, vol. 5, pp. 61-65, 1994.
- [13] G. Miller, A. Storey, S. V. Vadari, and K. Brewer, "Experiences using the dispatcher training simulator as a training tool," *IEEE Transactions on Power Systems*, vol. 8, pp. 1126-1132, 1993.
- [14] J. Waight, K. Nodehi, A. Bose, E. Dobrowolski, and R. Wasley, "Transportable simulator trains control centre operators," *Computer Applications in Power*, vol. 5, pp. 23-28, 1992.
- [15] F. Wang, G. Janka, and G. Schellstede, "Dynamic power system simulation for real time dispatcher training," Third International Conference on Power System Monitoring and Control, 1991.109-114
- [16] Working Group, "Hydraulic turbine and turbine control models for system dynamic studies," *IEEE Trans Power Systems*, vol. 7, pp. 167-179, 1992.
- [17] J. Douglas, J. Gasiorek, and J. Swaffield, *Fluid mechanics*. Harlow, Essex: Longman Scientific and Technical, 1995.